



**INTERNATIONAL JOURNAL OF ENGINEERING SCIENCES & RESEARCH  
TECHNOLOGY**

**Grid Interconnection of Renewable Energy Sources with Power-Quality Improvement  
Features**

**Mohin Ahamed Syed\*, M D Sulthana Zama, N. Ganesh**

PG Scholar, Dept. of EEE, Asst.Prof, Dept. of EEE,M.tech , Associate Professor (Ph.d),  
Siddhartha Institute of Technology and Sciences Narapally, Hyderabad, TS, India

---

**Abstracts**

A Power quality problem is an occurrence of nonstandard voltage, current or frequency that results in a failure or a misoperation of end user equipments. Utility distribution networks, sensitive industrial loads and critical commercial operations suffer from various types of outages and service interruptions which can cost significant financial losses. With the increase in load demand, the Renewable Energy Sources (RES) are increasingly connected in the distribution systems which utilizes power electronic Converters/Inverters. This paper presents a novel control strategy for achieving maximum benefits from these grid-interfacing inverters using the closed loop fuzzy logic control, when installed in 3-phase 4-wire distribution systems. The inverter is controlled to perform as a multi-function device by incorporating active power filter functionality. The inverter can thus be utilized as: 1) power converter to inject power generated from RES to the grid, and 2) shunt APF to compensate current unbalance, load current harmonics, load reactive power demand and load neutral current. All of these functions may be accomplished either individually or simultaneously. This new control concept is demonstrated with extensive MATLAB/Simulink.

**Keywords:** Photo Voltaic Active Power Filter, Shunt Active Power Filter, Power Quality.

---

**Introduction**

Due to increasing air pollution, global warming concerns, diminishing fossil fuels and their increasing cost have made it necessary to look towards Renewable Energy Sources (RES) as a future energy solution. In finding solutions to overcome a global energy crisis, the Photo Voltaic (PV) system has attracted significant attention in recent years. The government is providing incentives for further increasing the use of grid-connected PV systems. Renewable Energy Sources are increasing integrated at the distribution level due to increase in load demand which utilize power electronic converters. Due to the extensive use of power electronic devices, disturbances occur on the electrical supply network. These disturbances are due to the use of non-linear devices. These will introduce harmonics in the

power system thereby causing equipment overheating ,damage devices ,EMI related problems etc. Active Power Filters (APF) is extensively used to compensate the current harmonics and load unbalance. This will result in additional hardware requirements. So, in this paper, the existing PV inverter acts as Shunt Active Power Filter (SAPF) that is capable of simultaneously compensating problems like current unbalance, current harmonics and also of injecting the energy generated by RES. The shunt active filter is a voltage source inverter (VSI), which is connected in parallel with load. Shunt Active Power Filter has the ability to keep the mains current balanced and sinusoidal after compensation for various Load conditions.

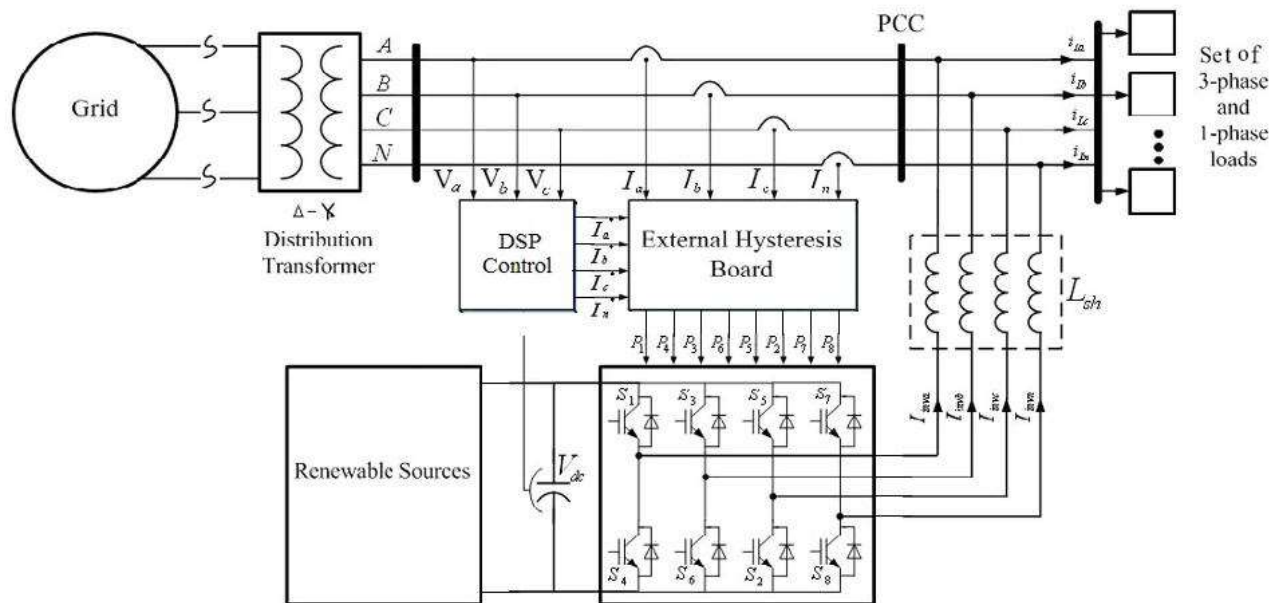

4-Leg Grid Interfacing Inverter

**System description**

The proposed system consists of RES connected to the dc-link of a grid-interfacing inverter as shown in Fig. 1. The voltage source inverter is a key element of a DG system as it interfaces the renewable energy source to the grid and delivers the generated power. The RES may be a DC source or an AC source with rectifier coupled to dc-link. Usually, the fuel cell and photovoltaic energy sources generate power at variable low dc voltage, while the variable speed wind turbines generate power at variable ac voltage. Thus, the power generated from these renewable sources needs power conditioning (i.e., dc/dc or ac/dc) before connecting on dc-link [6]–[8]. The dc-capacitor decouples the RES from grid and also allows independent control of converters on either side of dc-link.

**A. DC-Link Voltage and Power Control Operation:**

Due to the intermittent nature of RES, the generated power is of variable nature. The dc-link plays an important role in transferring this variable power from renewable energy source to the grid. RES are represented as current sources connected to the dc-link of a grid-interfacing inverter. Fig. 2 shows the systematic representation of power transfer from the renewable energy resources to the grid via the dc-link. The current injected by renewable into dc-link at voltage level Vdc can be given as

$$I_{dc1} = \frac{P_{RES}}{V_{dc}}$$

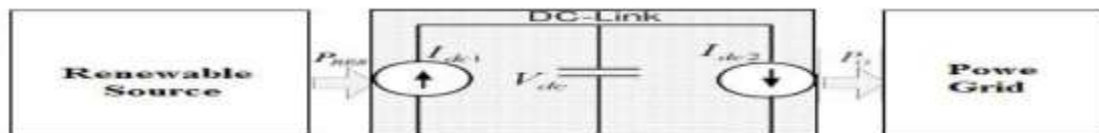

Fig 1.0 DC Equivalent

**Hysteresis current control**

The hysteresis current control (HCC) is the easiest control method to implement; it was developed by Brod and Novotny in 1985. The shunt APF is implemented with three phase current controlled VSI and is connected to the ac mains for compensating the current harmonics. The VSI gate control signals are brought out from hysteresis band current controller. A hysteresis current controller is implemented with a

closed loop control system and waveforms are shown in Fig. 3. An error signal is used to control the switches in a voltage source inverter. This error is the difference between the desired current and the current being injected by the inverter. If the error exceeds the upper limit of the hysteresis band, the upper switch of the inverter arm is turned off and the lower switch is turned on. As a result, the current starts decaying.

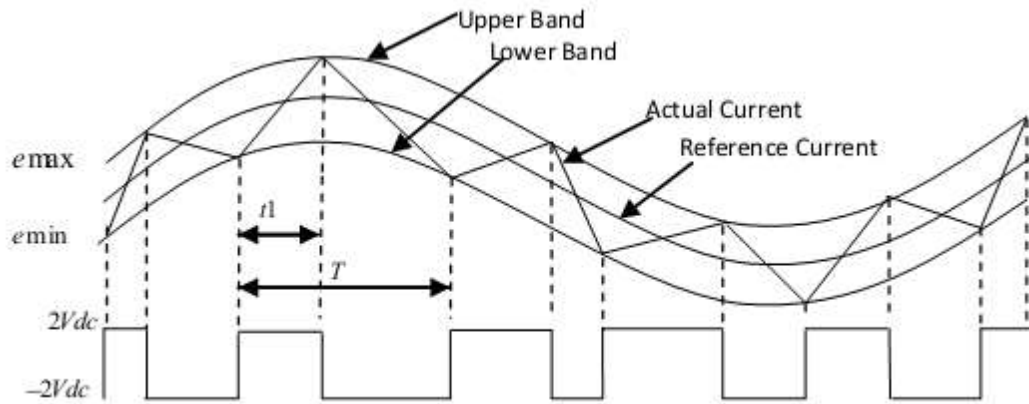

Fig 2.0 waveforms of Hysteresis

**Simulation results**

The performance of the proposed structure is assessed by a computer simulation that uses MATLAB

Software. The parameters of the proposed system are given in the tables below. The performance of the system with proposed control scheme is discussed, which includes the following case studies.

**CASE 1: NONLINEAR LOAD**

**a. Source Current**

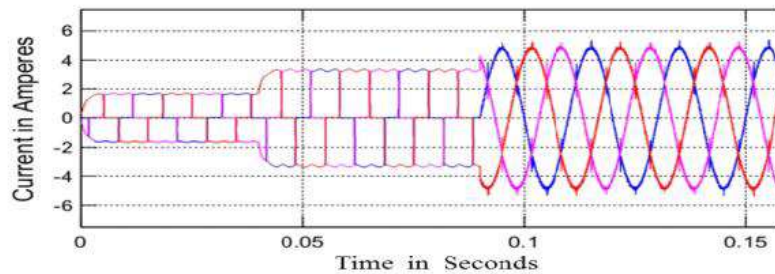

**b. Load Current**

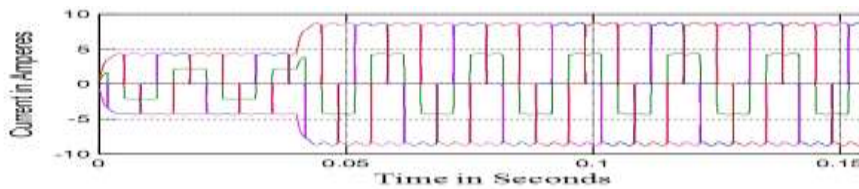

**c. INVERTER CURRENT**

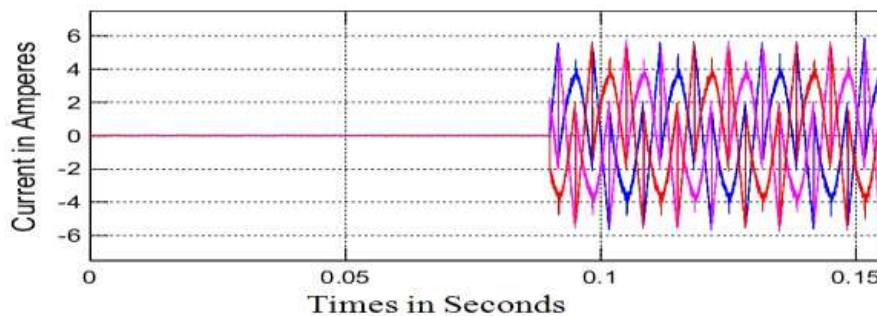

Fig 3.0 Simulation Results

### Conclusion

This paper has presented a novel control of an existing grid-interfacing inverter to improve the quality of power at PCC for a 3-phase 4-wire DG system. It has been shown that the grid-interfacing inverter can be effectively utilized for power conditioning without affecting its normal operation of real power transfer. The grid-interfacing inverter with the proposed approach can be utilized to: i) inject real power generated from RES to the grid, and/or, ii) operate as a shunt Active Power Filter (APF). This approach thus eliminates the need for additional power conditioning equipment to improve the quality of power at PCC. Extensive MATLAB/Simulink simulation. When the power generated from RES is more than the total load power demand, the grid-interfacing inverter with the proposed control approach not only fulfills the total load active and reactive power demand (with harmonic compensation) but also delivers the excess generated sinusoidal active power to the grid at unity power factor.

### References

1. J. M. Guerrero, L. G. de Vicuna, J. Matas, M. Castilla, and J. Miret, "A wireless controller to enhance dynamic performance of parallel inverters in distributed generation systems," *IEEE Trans. Power Electron.*, vol. 19, no. 5, pp. 1205–1213, Sep. 2004.
2. J. H. R. Enslin and P. J. M. Heskes, "Harmonic interaction between a large number of distributed power inverters and the distribution network," *IEEE Trans. Power Electron.*, vol. 19, no. 6, pp. 1586–1593, Nov. 2004.
3. U. Borup, F. Blaabjerg, and P. N. Enjeti, "Sharing of nonlinear load in parallel-connected three-phase converters," *IEEE Trans. Ind. Appl.*, vol. 37, no. 6, pp. 1817–1823, Nov./Dec. 2001.
4. P. Jintakosonwit, H. Fujita, H. Akagi, and S. Ogasawara, "Implementation and performance of cooperative control of shunt active filters for harmonic damping throughout a power distribution system," *IEEE Trans. Ind. Appl.*, vol. 39, no. 2, pp. 556–564, Mar./Apr. 2003.
5. J. P. Pinto, R. Pregitzer, L. F. C. Monteiro, and J. L. Afonso, "3-phase 4-wire shunt active power filter with renewable energy interface," presented at the Conf. IEEE Renewable Energy & Power Quality, Seville, Spain, 2007.
6. F. Blaabjerg, R. Teodorescu, M. Liserre, and A. V. Timbus, "Overview of control and grid synchronization for distributed power generation systems," *IEEE Trans. Ind. Electron.*, vol. 53, no. 5, pp. 1398–1409, Oct. 2006.
7. J. M. Carrasco, L. G. Franquelo, J. T. Bialasiewicz, E. Galván, R. C. P. Guisado, M. Á. M. Prats, J. I. León, and N. M. Alfonso, "Power electronic systems for the grid integration of renewable energy sources: A survey," *IEEE Trans. Ind. Electron.*, vol. 53, no. 4, pp. 1002–1016, Aug. 2006.
8. R. C. Dugan, M. F. McGranaghan, S. Santoso, H. W. Beaty, "Electrical Power Systems Quality", Second Edition, McGraw-Hill.
9. M. Aiello, A. Cataliotti, S. Favuzza, G. Graditi, "Theoretical and Experimental Comparison of Total Harmonic Distortion Factors for the evaluation of Harmonic and Inter harmonic Pollution of Grid-Connected." *IEEE Transactions On Power Delivery*, Vol. 21, No. 3, July 2006
10. J. M. A. Myrzik, and M. Calais, Member, IEEE "String and Module Integrated Inverters for Single-Phase Grid Connected Photovoltaic Systems – A Review". *Power Technical Conference Proceedings, 2003 IEEE Bologna*